



CLAWVAC

The new Benchmark
in Rough Vacuum



The new benchmark in rough vacuum

The CLAWVAC Family

The CLAWVAC's unique product features offer great advantages for the rough vacuum field. The pumps design enables extreme robustness, especially for challenging applications which include handling of particle and vapor contaminated gases. The user will experience a trouble-free and cost-saving operation.



Unique CLAWVAC features



Innovative Design

100% oil free compression pump chamber

- No oil migration into process
- No oil contamination

100% air cooled

- Extremely efficient air cooling for lowest operation temperature
- No demand for expensive cooling water
- Performance independent from water temperature

100% flexibility

- Variable speed drive (VSD) compatible
- Compact design with small footprint
- Cool running

100% environment friendly

- Low noise level
- Lowest power consumption
- Up to 50% energy saving by operation with VSD

100% operation safety

- Continuous operation at any inlet pressure without overheating
- Most robust bearing and seal design

Completely Cleanable

The user has full access to all media touched surfaces.

Housing and claws can be disassembled without need for resetting of gear timing.

The Built-in silencer allows condensate draining and can be removed and opened for cleaning.

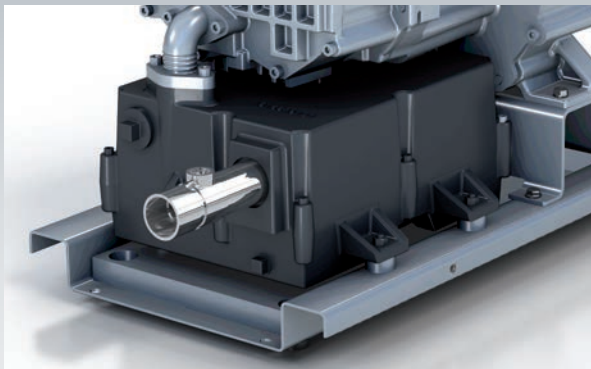
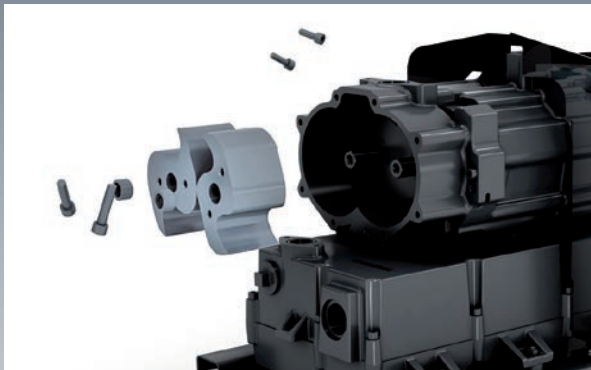

Minimal Downtime



Built-in corrosion resistance:

Highest capability also for demanding applications by

- Corrosion resistant stainless steel claws
- Coated pumping chamber

Lowest maintenance demand:

- 20,000 hour between oil changes
- Major overhauls extended to 48,000 hours

TYPICAL MARKETS:

Food Processing

- Bottling
- Dairy products (e.g. milking)
- Vacuum conveying (e.g. in slaughterhouse)
- Beverage production

Food Packaging

- Thermoforming of foil container
- Tray sealing
- Modified Oxygen Packaging (MAP)

Woodworking

- Holding & lifting
- CNC router
- Drying & impregnation

Material Transport & Holding

- Print & paper (press & post-press)
- Vacuum conveying
- Vacuum clamping

Degassing

- Li-battery slurry
- Ceramics & bricks

Thermoforming

- Deep drawing e.g. of bath tubs

Plastic Industry

- Composite manufacturing
- Granulate conveying
- Extruder degassing (e.g. PP, PE, PS)
- Gluing

Environmental Engineering

- Sewage degassing
- Biogas production
- Soil remediation

The new benchmark
in rough vacuum for
demanding industrial
applications



Performance, Technical Data and Dimensions

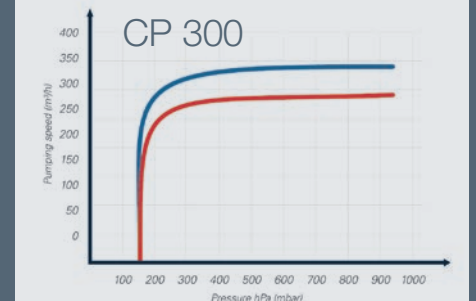
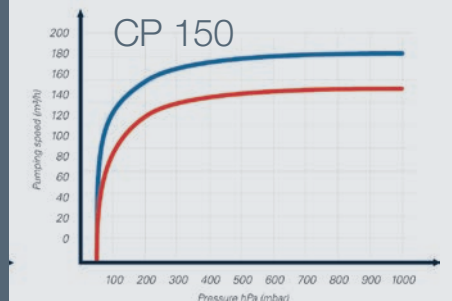
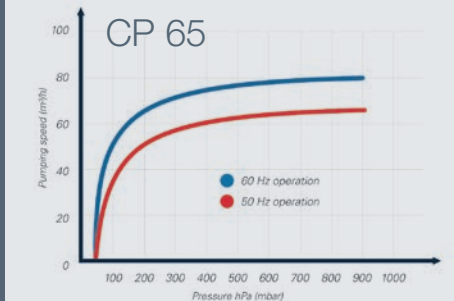

	CP 65	CP 150	CP 300
Pumping Speed (m³/h) 50/60Hz	65/78	150/180	300/360
Ultimate Vacuum (mbar)	50	50	140
Continuous Operation range (mbar)	50-1000	50-1000	140-1000
Connections	Inlet: G 1 1/4" or NPT Outlet: G 1 1/4" or NPT	Inlet: G 1 1/4" or NPT Outlet: G 1 1/4" or NPT	Inlet: G 2" or NPT Outlet: G 1 1/4" or NPT
Motor size* 50 Hz, 400V 60 Hz, 460V (kW)	1.8 2.2	3,7 3,7	6,2 7,5
Operation range (Hz)	20-60	20-60	20-60

*other voltages available

CP 65 and CP 150

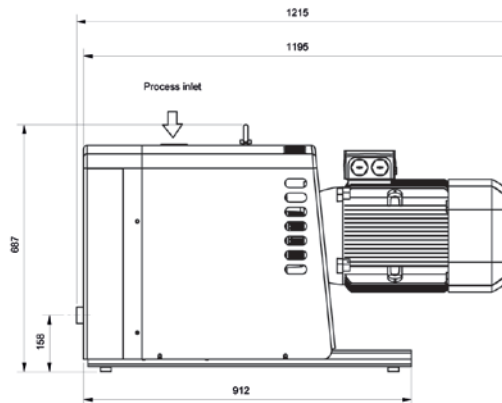
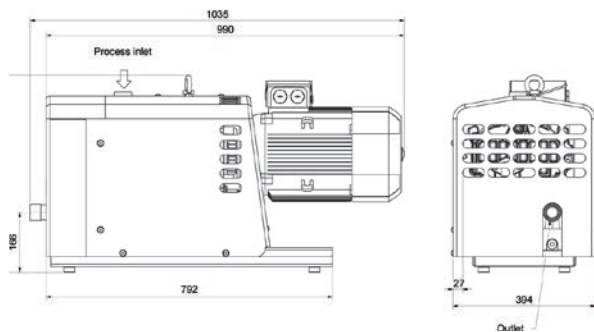

CP 300

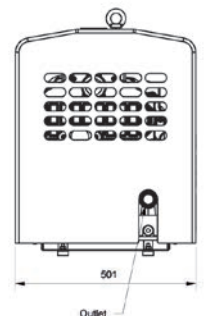

Leybold

Leybold GmbH
Bonner Str. 498 · D-50968 Köln
T +49 (0) 221-347-0
F +49 (0) 221-347-1250
info@leybold.com
www.leybold.com

